



The Edge Protection Federation Containment Systems – Product Specification, Test Methods

Revision 2

August 2016

This Standard defines how the Edge Protection Federation defines Containment.

This document is based on the Combisafe Containment Standard, who have kindly agreed to the adoption of their Standard by the EPF for the benefit of the wider industry.

It also defines how Containment is designed, tested and calculated.

Contents list

Foreword	Page 2
Introduction	Page 2
1 Scope	Page 3
2 Normative References	Page 3
3 Definitions	Page 4
4 Classification	Page 4
5 Requirements	Page 5
6 Structural design	Page 6
7 Verification by test	Page 9
8 Designation	Page 13
9 Marking and labelling	Page 13
10 Information to be given to the site	Page 13



The Edge Protection Federation

Containment System Standard – Product Specification, Test Methods

Revision 2: August 2016

Foreword

No existing European Standard is currently available for this type of product. The reason that this Standard has been developed, is to create an understanding and base for this type of products.

It is intended that this EPF Standard shall represent the types of Containment Systems offered by members of the Edge Protection Federation.

Introduction

Containment Systems are used in construction work, primarily to prevent persons and objects from falling to a lower level, from edges and other areas where protection is required. However, this standard does not replace fully or partly BS EN 13374: 2013 – Temporary edge protection systems – Product specification – Test methods, but is a complement to it.

In several European countries there is a wish to develop traditional Edge protection into what is called Containment in order to make the building industry safer.

BS EN 13374 includes requirements to protect people and objects from falling from height, e.g. through the provision of toeboards. There could however be circumstances where this is insufficient and additional measures, which are beyond the scope of that document, will need to be taken. The intention is to cover these demands in this document.

Classes specified in this document are intended to cater for the varied requirements appropriate for different uses.

It is important that the structure, to which temporary edge protection is attached, can support the forces for which the system is designed.

1.0 Scope

This EPF Standard specifies the requirements and test methods for Containment Systems in use during the construction or maintenance of buildings and other structures.

This standard applies to flat surface Containment Systems and specifies the requirements for different zones, sizes of debris and different wind classes.

This standard includes Containment Systems that are attached to the structure, and those that rely upon friction.

This standard does not provide requirements for Containment Systems intended for:

- protection against impact from vehicles or from other mobile equipment
- protection from sliding down of bulk materials, loose materials, snow etc.
- protection of the general public from falling

This standard does not apply to side protection systems on scaffolds.

2.0 Normative References

This Standard incorporates by dated or undated reference, provisions from other publications. These normative references are cited at the appropriate place in the text, and the publications are listed hereafter. For dated references, subsequent amendments to or revisions of any of these publications apply to this Standard only when incorporated in it by amendment or revision. For undated references, the latest edition of the publication referred to applies.

BS EN 74-1: 2005 – Couplers, spigot pins and baseplates for use in falsework and scaffolds – Couplers for tubes – Requirements and test procedures.

BS EN 338: 2016 – Structural timber - Strength classes.

BS EN 364: 1993 – Personal protective equipment against falls from a height – Test methods.

BS EN 596: 1995 – Timber structures – Test methods – Soft body impact test of timber framed walls

BS EN 1263-1: 2004 – Temporary works equipment – Safety nets – Safety requirements, test methods

BS EN 12811-2: 2004 – Temporary works equipment – Information on materials.

BS EN 12811-3: 2002 – Temporary works equipment – Load testing.

BS EN 13374: 2013 – Temporary edge protection systems – Product specification – Test methods.

BS EN 1990: 2002+A1: 2005 – Eurocode — Basis of structural design.

BS EN 1991-1-4: 2005+A1: 2010 – Eurocode 1 – Actions on structures – General actions – Wind actions.

BS EN 1993-1-1: 2005+A1: 2014 – Eurocode 3 – Design of steel structures - General rules and rules for buildings.

BS EN 1995-1-1: 2004+A2: 2014 – Eurocode 5 – Design of timber structures – General – Common rules and rules for buildings.

BS EN 1999-1-1:2007+A2: 2013 – Eurocode 9 – Design of aluminium structures – General structural rules.

3.0 Definitions

For the purposes of this EPF Standard the following definitions apply.

- 3.1 **Containment:** Containing persons and material inside the building and preventing them from falling out from an edge.
- 3.2 **Containment System:** Set of components intended to protect people and materials from falling to a lower level.
- 3.3 **Full containment:** Not used!
- 3.4 **Full height Containment:** Containment from floor to soffit.
- 3.5 **Containment zone:** Different floor heights where different type of construction work is carried out
- 3.6 **Containment area (C_a):** Different vertical area in one floor, i.e. between floor and soffit.
- 3.7 **Containment porosity (C_p):** The porosity of the containment, i.e. the size of material that can pass through.
- 3.8 **Containment wind class (C_q):** The wind velocity pressure to be used in calculations and tests.
- 3.9 **Working surface:** Surface, on which persons stand, walk or work.
- 3.10 **Falling height:** The vertical distance between the point on which a person stands and the lowest point on the protection intended to arrest any fall.

4.0 Classification

4.1 Containment area (C_a)

The area between floor and soffit is defined in three different areas and can be covered with different types of containment systems.

C_a 1: From floor to a minimum of 1 m above floor. Normally edge protection according to BS EN 13374 but can include higher containment density.

C_a 2: From 1m up to 2 m above floor. The area where material can be dropped above area 1 while standing on the floor. For people to fall in this area they need to stand above the floor. Also airborne material can hit this area.

C_a 3: From 2 m to soffit. The area where dropped material or people falling, only occurs when above floor level. Also air born material can hit this area. This area is normally only covered when work has to be done to columns at height from floor or work on soffit.

4.2 Containment porosity (C_p)

The containment porosity varies depending on need. The containment porosity (C_p) is defined by the size of a theoretical sphere that would be retained.

The following 5 classes are typical:

C_p 250: Containing material above 250 mm in size

C_p 100: Containing material above 100 mm in size

C_p 60: Containing material above 60 mm in size

C_p 20: Containing material above 20 mm in size

C_p 5: Containing material above 5 mm in size

4.3 Containment wind class (C_w)

Defined in chapter 6.3.3 Wind forces.

5.0 Requirements

5.1 General

5.1.1 Basic requirements

A Containment System shall comprise of a surface or structure that has a defined height and openings according to classes for Containment area (C_a) and Containment Porosity (C_p).

If it is possible for persons to fall from an edge, the Containment System shall be additional to or be combined with edge protection according to BS EN 13374.

Material containment shall be able to stop hand held material from falling out. With hand held material means material that can be manhandled and weighing maximum 20 kg, e.g. tools, props, bolts nuts or building material such as cladding brackets etc.

The inclination of the Containment shall not be more than 15 degrees from the vertical. The inclination of the working surface shall not be more than 10 degrees outwards.

5.2 Material

5.2.1 General

Material shall be in accordance with appropriate European Standards. Other materials shall fulfil the requirements given in European Standards. If European Standards do not exist, ISO standards may be applied.

Materials shall be sufficiently robust and durable to withstand normal working conditions.

Materials shall be free from any impurities and defects, which may affect their satisfactory use.

Information about the most commonly used materials is given in BS EN 12811-2. Material requirements for nets are given in BS EN 1263-1.

5.2.2 Steel

Steel of deoxidation type FU (rimming steels) shall not be used.

Information on common types of corrosion protection is given in BS EN 12811-2.

Where it is intended to use couplers in accordance with BS EN 74-1, the tubes shall have a minimum nominal yield stress of 235 N/mm² and a minimum nominal wall thickness of 3.2 mm.

5.2.3 Aluminium

Where it is intended to use couplers in accordance with BS EN 74-1, the tubes shall have a minimum nominal 0,2 % proof stress of 195 N/mm² and a minimum nominal wall thickness of 4,0 mm.

5.2.4 Timber

Timber shall be stress graded in accordance with BS EN 338 to have a minimum classification of C16.

If a protective coating is used, it shall not prevent the discovery of defects in the material.

6.0 Structural design

6.1 General

6.1.1 Method of design

If not specified otherwise the design has to be carried out following the limit state method. All loads specified in this standard shall be treated as characteristic loads.

Note: Characteristic loads means that partial safety factors shall be applied.

The Containment System, as well as each component, shall fulfil the load requirements separately.

Where it is not possible to verify the design according to the static load requirements by calculation, verification by testing shall be carried out.

Design shall be carried out in accordance with the European Standards for structural engineering. The current standards include:

For steel: BS EN 1993-1-1: 2005+A1: 2014 – Eurocode 3 – Design of steel structures - General rules and rules for buildings.

For aluminium: BS EN 1999-1-1:2007+A2: 2013 – Eurocode 9 – Design of aluminium structures – General structural rules.

For timber: BS EN 1995-1-1: 2004+A2: 2014 – Eurocode 5 – Design of timber structures – General – Common rules and rules for buildings.

For design: BS EN 1990: 2002+A1: 2005 – Eurocode — Basis of structural design.

If there are conflicts between provisions in this standard and other standards, e.g. ENs, then the provisions in this standard shall have precedence.

When using BS EN 1995-1-1 the following characteristics shall be used:

Load duration:

- Instantaneous for accidental load.
- Short term duration for other loads.

Service class:

- Class 2.

Modulus of elasticity:

- E_{mean} for serviceability limit state.
- $E_{0,05}$ for ultimate limit state.

6.2 Partial safety factors

6.2.1 Ultimate limit state

For the ultimate limit state, partial safety factors shall be:

- $\gamma_F = 0,9$ for favourable loads, e.g. friction
- $\gamma_F = 1,5$ for all permanent and variable loads
- $\gamma_M = 1,1$ for ductile metallic materials (definition of ductility see BS EN 12811-2)
- $\gamma_M = 1,25$ for brittle metallic materials
- $\gamma_M = 1,3$ for timber

6.2.2 Limit state for accidental actions

For the accidental actions given in 6.3.4, partial safety factors shall be:

- $\gamma_F = 1,0$ for loads F_D
- $\gamma_M = 1,0$ for all materials

6.3 Static loads

6.3.1 Static load F_H perpendicular to the Containment System

6.3.1.1 General

The Containment System and any of its components, shall be designed to withstand a load $F_{H1} = 0.3$ kN applied perpendicular to the edge.

6.3.1.2 Nets

The fixing of each net shall satisfy the static load requirement.

6.3.1.3 Area of application

The loads referred to above are essentially point loads but they shall be assumed to be distributed upon a maximum area of 100 mm x 100 mm. For a net or a fencing structure, this load shall be assumed to be uniformly distributed upon a maximum area of 300 mm x 300 mm.

6.3.2 Static load parallel to the Containment System

The Containment System and any of its components, shall be able to withstand a horizontal load of 0.2 kN in its worst position.

6.3.3 Wind forces

Wind forces, F_w , shall be calculated by assuming a wind velocity pressure to be applied on an effective area of the Containment System, which in general is the projected area in the wind direction, not taking shielding into account. They shall be determined as follows:

$$F_w = \Sigma (\alpha_{i,i} \cdot q_i \cdot A_i)$$

where:

- F_w is the resulting wind force
- $\alpha_{i,i}$ is the aerodynamic force coefficient for the edge protection components i (C_{f0} may be used uncorrected)
- q_i is the wind velocity pressure acting on the edge protection components i
- A_i is the reference area of the edge protection components i

The wind velocity pressure, q_i , can be chosen according to intended use, be calculated to specific conditions or for simplicity use the following classes C_q :

$$C_q \ 350; \ q_i = 350 \text{ N/m}^2$$

Note: the wind velocity pressure $q_i = 350$ N/m² represents a wind speed of approximately 24 m/s. This covers wind speeds up to storm.

$$C_q \ 600; \ q_i = 600 \text{ N/m}^2$$

Note: This covers most wind conditions in Europe. More onerous conditions may occur. The wind velocity pressure $q_i = 600$ N/m² represents a wind speed of approximately 32 m/s. This covers wind speeds up to hurricane.

Note: The aerodynamic force coefficient $c_{f,i}$ appropriate to the cross section of the edge protection components in question is given in BS EN 1991-1-4.

For cross sections not included in BS EN 1991-1-4, the aerodynamic force coefficient may not be assumed to be less than 2.0, or it shall be verified by testing.

When wind load is the governing load case, i.e. its effects are greater than the effect of the 300 N, see 6.3.1, the Containment System shall prove to withstand the wind load.

6.3.4 Accidental loading

Any part of the system, regardless of its method of support, shall be capable of resisting a downwards point load $F_D = 1.25$ kN on a length of 100 mm. This applies where any other component of the systems, such as a fencing structure, has gaps in excess of 100 mm width.

This load shall be applied in the most unfavourable position of the edge protection system in a downward direction within a sector of $\pm 10^\circ$ from the vertical.

6.4 Dynamic load

The Containment System shall be capable of absorbing a kinetic energy of 200J anywhere along the protection. To fulfil this requirement, Containment Systems shall withstand the dynamic strength test described in 7.5

The system does not need to be serviceable after the test.

7.0 Verification by Test

7.1 General

The test shall be carried out in accordance with the requirements in clause 7 of this standard, and any relevant European standards shall be used. Unless otherwise indicated in the following, testing shall be conducted by way of visual examination and measurement.

Any testing laboratory shall be able to demonstrate competence to carry out the relevant testing requirements of this standard.

Note: Some countries have systems for national accreditation of testing laboratories.

7.2 Applying the load

The loading point shall be a maximum of 100x100 mm e.g. for smaller elements, the width of the element x 100 mm.

For net or fencing structures the distributing area shall be a maximum of 300mm x 300mm.

Stability of the test rig structure shall comply with 4.4 of BS EN 364 (the natural frequency shall not be lower than 100 Hz and the deformation shall not exceed 1 mm in the fixing point at a force of 20kN).

7.3 Description for sample erection

The test sample shall comprise of at least one bay in the most unfavourable length of the Containment System or the worst possible configuration. Whichever the case, the test

sample shall be erected to represent the way it is intended to be erected during use on site, i.e. in accordance with the manufacturer's instructions.

Clamp type edge protection system, for general use, when used as support for Containment Systems, shall be tested on a piece of concrete slab. The slab sample shall have a thickness of 200mm ± 5mm.

For special applications, e.g. clamping to beam flanges, the edge protection system shall be tested in the way it is intended to be clamped.

7.4 Tests for conformity with static load requirements

7.4.1 General

A minimum of 3 separate representative samples shall be tested in each type of test.

The tests shall be carried out taking into consideration the worst conditions it has been designed for, according to the manufacturer's instructions.

Treatment of results from tests shall be carried out in accordance with the method set out in Section 10.8 of BS EN 12811-3 where appropriate.

7.4.2 Tests for static strength

The loads shall be applied to the most adverse positions.

Record the datum position of the Containment System, δ_1 .

The system shall be loaded up to the maximum test load, F_{max} ($= \gamma_M \times \gamma_F \times Q_K$), where γ_M and γ_F are partial safety factors; and Q_K is the characteristic load for the case being considered.

The instantaneous deflection of the edge protection, δ_2 at this load shall be measured.

During this period of maximum load there should be no identifiable yielding, fracture or separation of any part of the assembly.

The test load shall be removed and the residual deformation on removal of the test load shall be measured.

The system should then be loaded up to the ultimate load, R_u , where there is identifiable failure in either the system as a whole or in one of its components.

7.4.3 Acceptance criteria

For the edge protection system under test to comply with the static strength requirements of this standard, the adjusted strength R_u (see 7.4.1) shall not be less than 1.2 times the maximum test load, F_{max} .

7.5 Tests for conformity with dynamic load

7.5.1 General

Prior to each test commencing, ensure that the system is properly bedded and that any slack in the system etc., is taken out.

7.5.2 Test Procedure

A sphericonical bag shall be released in a controlled fall under gravity and swung towards the Containment System at critical points, see figure 1, e.g. on the supports and in the middle of the system, to check if the test sample has adequate resistance to withstand the impact.

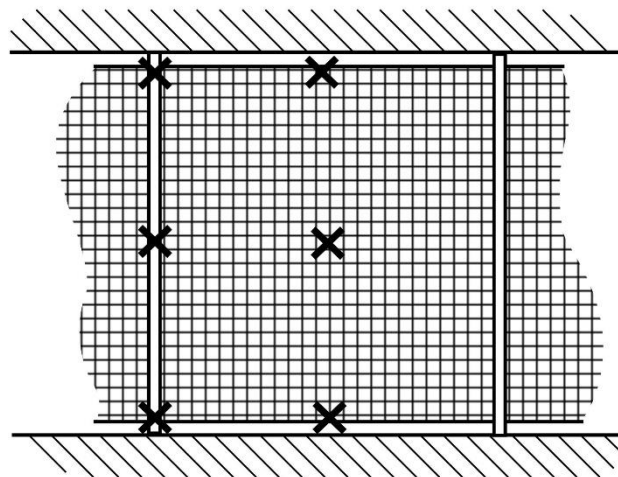

Figure 1 – Typical Critical Points

The impact is obtained by the pendulum fall of the sphericonical bag which is vertical at the impact point. The impacting body shall be held back to avoid a second impact.

7.5.2.1 Test rig

A typical test apparatus is shown in figure 1. The sphericonical bag is suspended by its ring to a rope, C_1 , passing over a pulley, P_1 . P_1 shall be attached to the frame in the position which ensures that:

- when the bag is offered up to the test specimen its centre touches the specimen at the required point
- the angle, α , between the rope, C_1 , and the point of impact is less than 65° when the bag is at its starting position
- at the point of impact the rope shall be within $\pm 5^\circ$ from the vertical.

7.5.2.2 The sphericonical bag

The sphericonical bag shall (have a total mass 20 kg. It shall comprise a spherical leather bag of diameter approximately 400 mm), be in accordance with BS EN 596. The sphericonical bag shall be connected to the rope by a device, C_2 , which can be released instantaneously from a distance.

7.5.2.3 Test drop height

To fulfil the requirements in clause 6.4 the drop height, see figure 2, shall be 1 m.

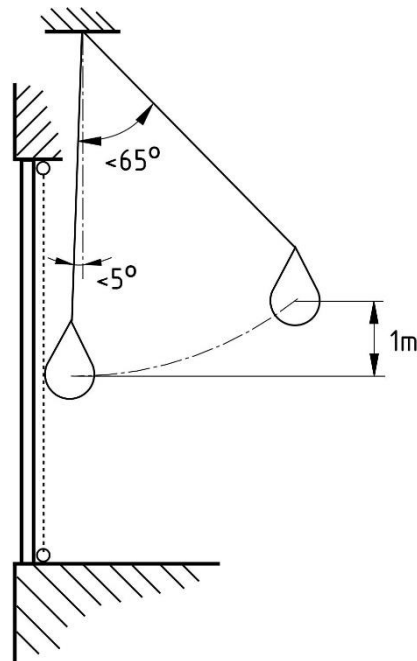

Figure 2 – Test apparatus for impact test

7.5.2.4 Test procedure

Raise the sphericonical bag to its starting position. Release the sphericonical bag and allow it to impact with the Containment System.

7.5.2.5 Acceptance Criteria

For the system under test to comply with the dynamic strength requirements of this standard, the sphericonical bag shall be arrested by the Containment System.

7.6 Test reports

The test reports shall follow the outlines given in BS EN 12811-3 Clause 9 but shall include at least the following:

- a description of the configuration of the Containment System
- the number, title and date of issues of this EPF standard
- a description of the sample including material specification
- photographs of and description of the test rig structure
- a description of the foundation during the test
- a detailed description of the entire test procedure
- the test result
- the confirmation that the tests were carried out in accordance with this standard.

8.0 Designation

Example of designation for a Containment System

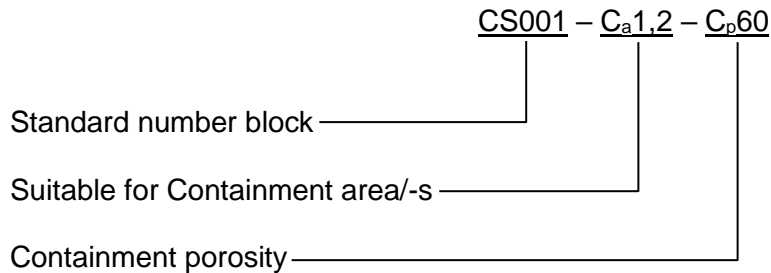

9.0 Marking and Labelling

The main components shall be marked, e.g. Posts/Props, Net or fencing structures. The marking shall be clearly visible and shall be so arranged that it will remain legible for the service life of the product, and contain the following:

- CS001
- Containment areas it is suited for, C_a1, 2, 3
- Containment Porosity, C_p XX
- Name / identification of the manufacturer or supplier
- Year and month, in that order, of manufacture or serial number

Other components e.g. timber etc. shall be marked according to the relevant standard.

10.0 Information to Be Given to The Site

10.1 General requirements

A set of instructions forming a manual shall be provided. They will be part of the basis of the assessment and, after successful completion; their content shall be supplied with the components as part of the Containment System.

10.2 Principal contents

The main instructions shall include:

- a list giving each component and a description from which it can be identified e.g. with a drawing
- instructions for the sequence of assembling and dismantling the components and for the way to handle them
- layouts of configurations proposed
- a statement of limitations of use with reference to wind velocity pressure, ice and snow
- a full specification of the items which are not purpose made components
- loads imposed on the structure from which it is supported
- criteria for rejecting components which are worn or damaged
- any instructions for storage, maintenance or repair which the manufacturer considers appropriate

- information about applications for which the Containment System is suitable, according to relevant rules

The instructions shall also state the following:

- after a fall of a person or an object towards or into the Containment System, and its accessories, the system shall only be re-used after having been inspected by a competent person